

Platen Clamps & Hold Down Clamps

Hold down action clamps with unique features and accessories.

Modular Platen Clamps

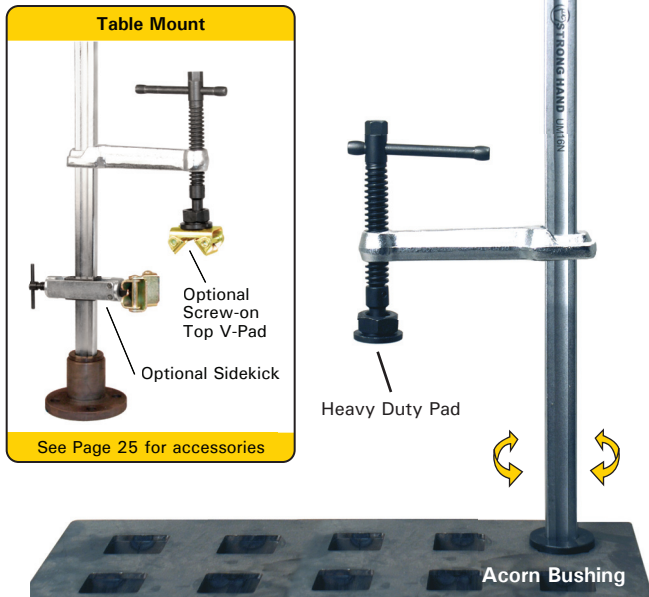

For fast, secure clamping, simply insert the clamp into the 1-3/4" square hole in your acorn platen. Slide the clamp arm down to the work piece and turn the T-Handle to tighten.

- » Choose from Acorn Bushing or Table Mount Models.
- » Clamp comes with standard or heavy duty Swivel Pads.
- » Unique optional Side-Kick Attachment provides push-action horizontal clamping force. (See accessories page)
- » Optional V-Pads can be mounted on the Sliding Arm or Side-Kick Attachment. (See accessories page)

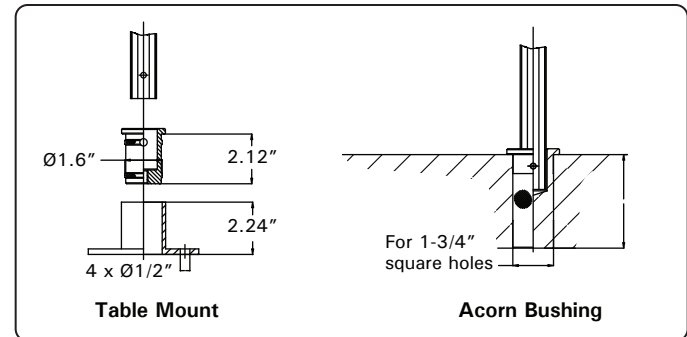

Table Mount

| Part No. | Rail Size | Pad | Opening | Throat |
|----------|-----------|------------|---------------|------------------|
| UF8NC | "F" | Standard | 8" 203 mm | 4-3/4" 120 mm |
| UF10NC | "F" | Standard | 10" 254 mm | 4-3/4" 120 mm |
| UF12NC | "F" | Standard | 12" 305 mm | 4-3/4" 120 mm |
| UM12NC | "M" | Heavy Duty | 12" 305 mm | 5-1/2" 140 mm |
| UM16NC | "M" | Heavy Duty | 16" 406 mm | 5-1/2" 140 mm |
| UM20NC | "M" | Heavy Duty | 20" 508 mm | 5-1/2" 140 mm |

Acorn Bushing

| Part No. | Rail Size | Pad | Opening | Throat |
|----------|-----------|------------|---------------|------------------|
| UF8NA | "F" | Standard | 8" 203 mm | 4-3/4" 120 mm |
| UF10NA | "F" | Standard | 10" 254 mm | 4-3/4" 120 mm |
| UF12NA | "F" | Standard | 12" 305 mm | 4-3/4" 120 mm |
| UM12NA | "M" | Heavy Duty | 12" 305 mm | 5-1/2" 140 mm |
| UM16NA | "M" | Heavy Duty | 16" 406 mm | 5-1/2" 140 mm |
| UM20NA | "M" | Heavy Duty | 20" 508 mm | 5-1/2" 140 mm |

NEW Hold Down Clamps

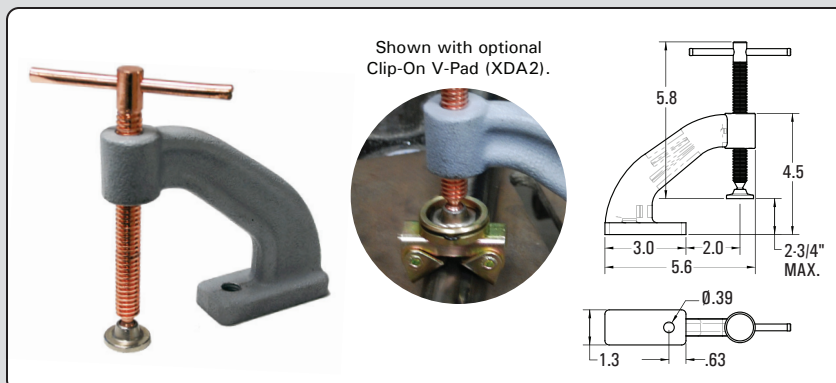

- » Bolt the clamp down to your worktable using the 3/8" hole in the base.
- » The 1/2" copper plated Acme spindle resists weld spatter, and the swivel tip makes quick contact with your workpiece.
- » Hold pipes by adding our Clip-On V-Pad, Part #XDA2. (See accessory page 26).

| Part No. | Capacity | Weight |
|----------|-----------------|-------------------|
| VHD30 | 2-3/4" 70 mm | 2.0 lbs 0.9 lb |

Copper Plated
Acme Screw /
Ductile Iron Body